

| RATING | Kgf/cm ² | PSI |
|--------|--------------------------|---------|
| BODY | 10.5 Kgf/cm ² | 149 PSI |
| SEAT | 7.7 Kgf/cm ² | 110 PSI |

| RATING | Kgf/cm ² | PSI |
|--------|--------------------------|---------|
| BODY | 10.5 Kgf/cm ² | 149 PSI |
| SEAT | 7.7 Kgf/cm ² | 110 PSI |

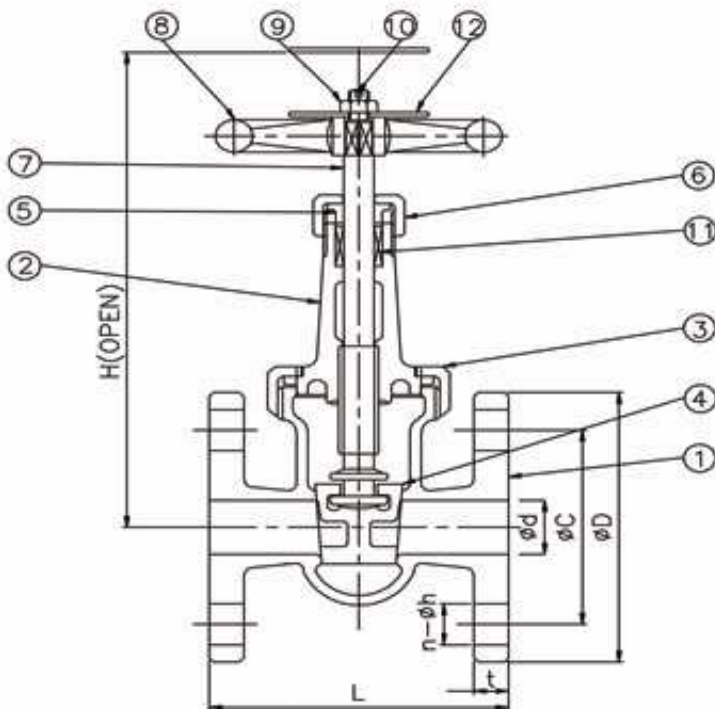

| | | |
|----|-------------------|--------------------|
| 12 | NAME PLATE | JIS H 3100-C2801P |
| 11 | PACKING | JIS F 7102 |
| 10 | SPLIT PIN | JIS H 3260-C2600W |
| 9 | HEXAGON NUT | JIS H 3250-C3604BD |
| 8 | HAND WHEEL | JIS G 5501-FC200 |
| 7 | STEM | JIS H 3250-C3771BD |
| 6 | PACKING GLAND NUT | JIS H 3250-C3771BD |
| 5 | PACKING GLAND | JIS H 3250-C3771BD |
| 4 | DISC | JIS H 5111-BC6 |
| 3 | BONNET NUT | |
| 2 | BONNET | |
| 1 | BODY | |

DIMENSION (5K:F7367, 10K:F7368)

(Unit:mm)

| SIZE | ød | L | | 5K FLANGE | | | | 10K FLANGE | | | | H | WEIGHT (kg) | |
|------|----|-----|-----|-----------|----|----|------|------------|-----|----|------|-----|-------------|------|
| | | 5K | 10K | øD | øC | t | n-øh | øD | øC | t | n-øh | | 5K | 10K |
| 15A | 15 | 90 | 100 | 80 | 60 | 9 | 4-12 | 95 | 70 | 12 | 4-15 | 175 | 2.29 | 2.96 |
| 20A | 20 | 100 | 110 | 85 | 65 | 10 | 4-12 | 100 | 75 | 14 | 4-15 | 200 | 2.98 | 3.89 |
| 25A | 25 | 110 | 120 | 95 | 75 | 10 | 4-12 | 125 | 90 | 14 | 4-19 | 220 | 4.10 | 5.82 |
| 32A | 32 | 140 | 140 | 115 | 90 | 12 | 4-15 | 135 | 100 | 16 | 4-19 | 250 | 5.79 | 7.52 |
| 40A | 40 | 140 | 150 | 120 | 95 | 12 | 4-15 | 140 | 105 | 16 | 4-19 | 290 | 7.78 | 9.72 |

CAST STEEL GATE 10K

| RATING | Kgf/cm ² | PSI |
|--------|--------------------------|---------|
| BODY | 21 Kgf/cm ² | 298 PSI |
| SEAT | 15.4 Kgf/cm ² | 219 PSI |

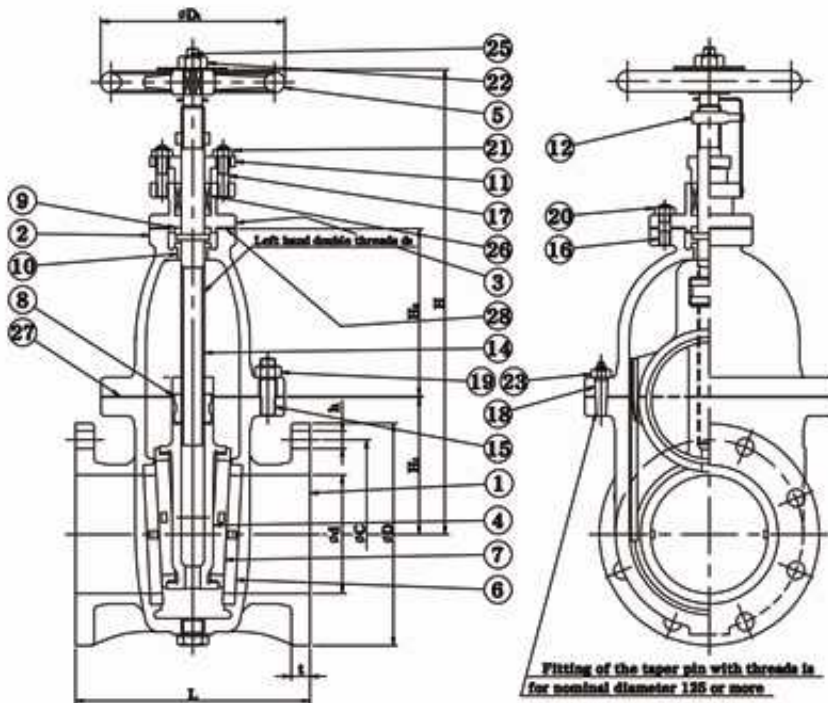

| | | |
|----|--------------------|---------------------|
| 28 | GASKET | JIS F 7102 |
| 27 | GASKET | JIS F 7102 |
| 26 | PACKING | JIS F 7102 |
| 25 | SPLIT PIN | JIS H 3260-C2600W |
| 24 | MACHINE SCREW | JIS H 3260-C2700W |
| 23 | HEXAGON NUT | |
| 22 | HEXAGON NUT | JIS H 3250-C3604B0 |
| 21 | HEXAGON NUT | |
| 20 | HEXAGON NUT | JIS G 3101-SS400 |
| 19 | HEXAGON NUT | |
| 18 | TAPER PIN WITH NUT | JIS G 4305-SUS304 |
| 17 | STUD BOLT | JIS H 3250-C3771B0 |
| 16 | STUD BOLT | |
| 15 | STUD BOLT | JIS G 3101-SS400 |
| 14 | STEM | JIS G 4303-SUS403 |
| 13 | INDICATOR PLATE | JIS H 3201-BsP 3-H |
| 12 | INDICATOR | JIS H 5111-BC6 |
| 11 | PACKING GLAND | JIS H 5111-BC6 |
| 10 | GUIDE BUSH | JIS H 5111-BC6 |
| 9 | GUIDE BUSH | JIS H 5111-BC6 |
| 8 | SCREWED PIECE | JIS H 5111-BC6 |
| 7 | VALVE SEAT OF DISC | JIS G 4303-SUS420J1 |
| 6 | VALVE SEAT OF BODY | JIS G 4303-SUS420J1 |
| 5 | HANDWHEEL | JIS G 5101-FC200 |
| 4 | DISC | JIS G 5101-SC480 |
| 3 | STUFFING BOX | |
| 2 | BONNET | JIS G 5101-SC480 |
| 1 | BODY | |

DIMENSION

(Unit:mm)

| SIZE | ød | FLANGE JIS10K FF | | | | L | H | H1 | H2 | ød6 | øD1 |
|------|-----|------------------|-----|-------|----|-----|-----|-----|-----|------|-----|
| | | øD | øC | n-øh | t | | | | | | |
| 50A | 50 | 155 | 120 | 4-19 | 16 | 200 | 300 | 80 | 96 | TW18 | 140 |
| 65A | 65 | 175 | 140 | 4-19 | 18 | 220 | 350 | 90 | 120 | TW20 | 160 |
| 80A | 80 | 185 | 150 | 8-19 | 18 | 230 | 400 | 115 | 127 | TW22 | 180 |
| 100A | 100 | 210 | 175 | 8-19 | 18 | 250 | 450 | 135 | 146 | TW24 | 200 |
| 125A | 125 | 250 | 210 | 8-23 | 20 | 270 | 520 | 155 | 176 | TW26 | 224 |
| 150A | 150 | 280 | 240 | 8-23 | 22 | 290 | 580 | 170 | 204 | TW28 | 250 |
| 200A | 200 | 330 | 290 | 12-23 | 22 | 310 | 700 | 210 | 258 | TW32 | 315 |
| 250A | 250 | 400 | 355 | 12-25 | 24 | 340 | 840 | 245 | 329 | TW38 | 400 |
| 300A | 300 | 445 | 400 | 16-25 | 24 | 380 | 960 | 275 | 392 | TW42 | 450 |

CAST IRON GATE VALVE 5K & 10K

| RATING | 5Kgf/cm ² | 10Kgf/cm ² |
|--------|----------------------|-----------------------|
| BODY | 10.5 | 21.0 |
| SEAT | 7.7 | 15.4 |

For nominal dia. 400

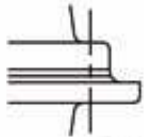

Detail "A"

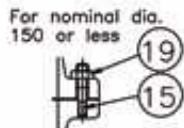

Detail "B"

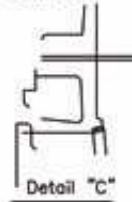
 For nominal
 doi. 400A

Detail "C"

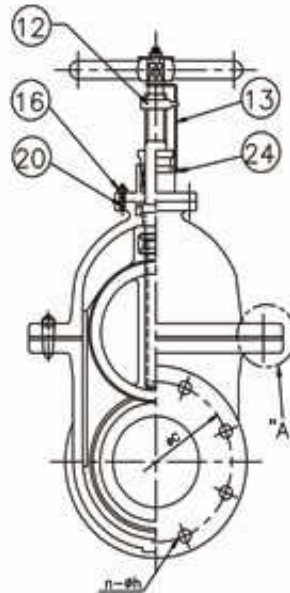
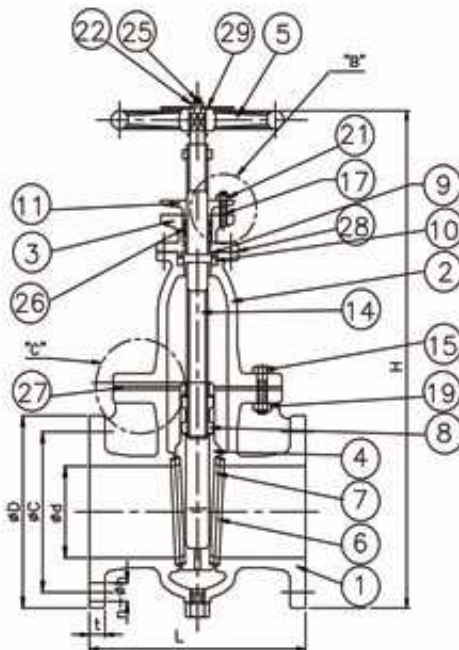

| | | |
|----|--|--------------------|
| 29 | NAME PLATE | JIS H 3100-C2801P |
| 28 | GASKET | |
| 27 | GASKET | JIS F 7102 |
| 26 | PACKING | |
| 25 | SPLIT PIN | JIS H 3260-C2600W |
| 24 | CROSS RECESSED PIN HEAD MACHINE SCREW | JIS H 3260-C2700W |
| 23 | HEXAGON NUT | |
| 22 | HEXAGON NUT | JIS H 3250-C3604BD |
| 21 | HEXAGON NUT | |
| 20 | HEXAGON NUT | JIS G 3101-SS400 |
| 19 | HEXAGON NUT | |
| 18 | TAPER PIN WITH THREAD | JIS G 4303-SUS403 |
| 17 | STUD | JIS H 3250-C3771BD |
| 16 | STUD | |
| 15 | HEXAGON BOLT | JIS G 3101-SS400 |
| 14 | STEM | JIS H 3250-BD, BE |
| 13 | INDICATOR PLATE | JIS H 3100-C2801P |
| 12 | INDICATOR | |
| 11 | PACKING GLAND | |
| 10 | GUIDE BUSH | BC 6 |
| 9 | GUIDE BUSH | |
| 8 | SCREWED PIECE | |
| 7 | DISC RING | |
| 6 | SEAT RING | |
| 5 | HANDWHEEL | FC 200 |
| 4 | DISC | |
| 3 | STUFFING BOX | FC200 |
| 2 | BONNET | |
| 1 | BODY | |

DIMENSION

(Unit:mm)

| SIZE | ød | FLANGE JIS20K RF | | | | | | | L1 | H | H1 | H2 | ød1 | d2 | øD2 |
|------|-----|------------------|-----|-----|---|-------|----|-----|-----|-----|-----|-----|------|-----|-----|
| | | øD | øC | øg | f | n-øh | t | | | | | | | | |
| 32A | 32 | 135 | 100 | 80 | 2 | 4-19 | 18 | 100 | 240 | 72 | 115 | 32 | TW20 | 160 | |
| 40A | 40 | 140 | 105 | 85 | 2 | 4-19 | 18 | 110 | 255 | 75 | 122 | 40 | TW22 | 160 | |
| 50A | 50 | 155 | 120 | 100 | 2 | 8-19 | 18 | 125 | 270 | 75 | 128 | 50 | TW24 | 200 | |
| 65A | 65 | 175 | 140 | 120 | 2 | 8-19 | 20 | 135 | 295 | 85 | 138 | 65 | TW26 | 224 | |
| 80A | 80 | 200 | 160 | 135 | 2 | 8-23 | 22 | 150 | 325 | 95 | 152 | 80 | TW30 | 250 | |
| 90A | 90 | 210 | 170 | 145 | 2 | 8-23 | 24 | 160 | 345 | 100 | 160 | 90 | TW32 | 280 | |
| 100A | 100 | 225 | 185 | 160 | 2 | 8-23 | 24 | 170 | 365 | 110 | 168 | 100 | TW34 | 280 | |
| 125A | 125 | 270 | 225 | 195 | 2 | 8-25 | 26 | 200 | 415 | 125 | 192 | 125 | TW38 | 315 | |
| 150A | 150 | 305 | 260 | 230 | 2 | 12-25 | 28 | 225 | 460 | 140 | 212 | 150 | TW42 | 355 | |
| 200A | 200 | 350 | 305 | 275 | 2 | 12-25 | 30 | 280 | 520 | 135 | 240 | 200 | TW50 | 450 | |
| 250A | 250 | 430 | 380 | 345 | 2 | 12-27 | 24 | 310 | 595 | 160 | 267 | 250 | TW58 | 560 | |