

BRONZE HOSE ANGLE VALVE 5K & 10K

RATING	Kgf/cm ²	PSI
BODY	10.5 Kgf/cm ²	149 PSI
SEAT	7.7 Kgf/cm ²	110 PSI

RATING	Kgf/cm ²	PSI
BODY	10.5 Kgf/cm ²	149 PSI
SEAT	7.7 Kgf/cm ²	110 PSI

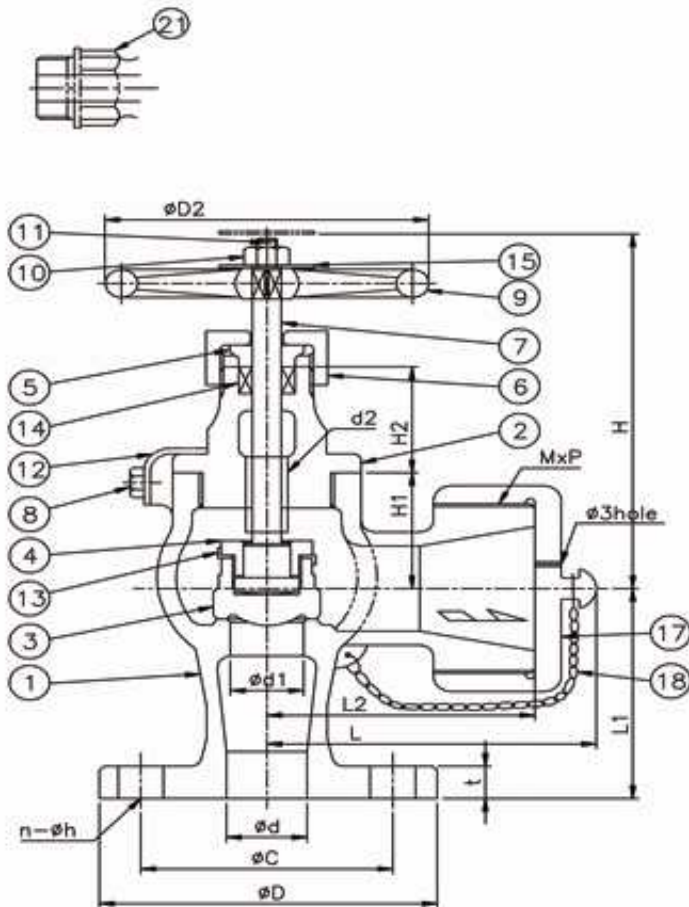

21	BODY	JIS H 5111-BC6
18	CHAIN	JIS F 7335
17	CAP	
15	NAME PLATE	JIS H 3100-C2801 P
14	PACKING	JIS F 7102
13	DISC LOCK WASHER	JIS H 3100-C2600 P
12	BONNET LOCK PLATE	
11	SPLIT PIN	JIS H 3260-C2600 W
10	HEXAGON NUT	JIS H 3250-C3604 BD
9	HANDWHEEL	JIS G 5501-FC200
8	CROSS RECESSED PAN HEAD MACHINE SCREW	JIS H 3260-C2700 W
7	STEM	JIS H 3250-C3771BDorBE
6	GLAND NUT	JIS H 5111-BC6 or JIS H 3250-C3771 BD or C3604 BD
5	PACKING GLAND	
4	DISC NUT	
3	DISC	JIS H 5111-BC6 or H 3250-C3771BDorBE
2	BONNET	
1	BODY	JIS H 5111-BC6

DIMENSION

(Unit:mm)

SIZE	ϕd	FLANGE JIS5K FF				L	L1	L2	H	H1	H2	$\phi d1$	d2	$\phi D2$	MxP
		ϕD	ϕC	n- ϕh	t										
15A	15	80	60	4-12	9	68	55	55	120	37	33	20	TW14	80	M42xP2
25A	25	95	75	4-12	10	78	65	65	145	44	43	30	TW18	125	M42xP2

SIZE	ϕd	FLANGE JIS10K FF				L	L1	L2	H	H1	H2	$\phi d1$	d2	$\phi D2$	MxP
		ϕD	ϕC	n- ϕh	t										
15A	15	95	70	4-15	12	73	70	60	120	37	33	20	TW14	80	M42xP2
25A	25	125	90	4-19	14	83	85	70	145	44	43	30	TW18	125	M42xP2

RATING	Kgf/cm ²	PSI
BODY	10.5 Kgf/cm ²	149 PSI
SEAT	7.7 Kgf/cm ²	109 PSI

RATING	Kgf/cm ²	PSI
BODY	21 Kgf/cm ²	299 PSI
SEAT	15.4 Kgf/cm ²	219 PSI

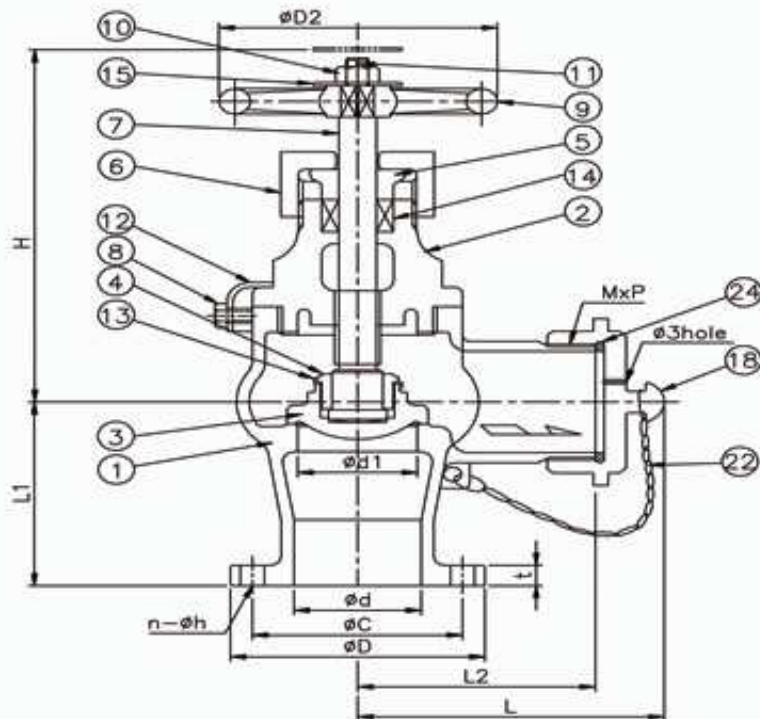

24	GASKET	
22	CHAIN	JIS F 7335
18	CAP	
15	NAME PLATE	JIS H 3100-C2801 P
14	PACKING	JIS F 7102
13	DISC LOCK WASHER	JIS H 3100-C2600 P
12	BONNET LOCK PLATE	JIS H 3250-C3771 BD or BE
11	SPLIT PIN	JIS H 3260-C2600 W
10	HEXAGON NUT	JIS H 3250-C3604 BD
9	HANDWHEEL	JIS G 5501-FC200
8	CROSS RECESSED PAN HEAD MACHINE SCREW	JIS H 3260-C2700 W
7	STEM	JIS H 3250-C3771BDorBE
6	GLAND NUT	JIS H 5111-BC6 or JIS H 3250-C3771 BD or C3604 BD
5	PACKING GLAND	
4	DISC NUT	
3	DISC	JIS H 5111-BC6 or H 3250-C3771BDorBE
2	BONNET	
1	BODY	JIS H 5111-BC6

DIMENSION

(Unit:mm)

SIZE	ød	FLANGE JIS5K FF				L1	L2	L	H	ød1	d2	øD2	MxP	WT(Kg) /EA
		øD	øC	n-øh	t									
40A	40	120	95	4-15	12	85	75	98	190	45	TW20	140	ø50.5-9TPI	5.91

SIZE	ød	FLANGE JIS10K FF				L1	L2	L	H	ød1	d2	øD2	MxP	WT(Kg) /EA
		øD	øC	n-øh	t									
40A	40	140	105	4-19	16	100	75	98	190	45	TW20	140	ø50.5-9TPI	8.19

BRONZE HOSE ANGLE VALVE 5K & 10K

RATING	Kgf/cm ²	PSI
BODY	10.5 Kgf/cm ²	149 PSI
SEAT	7.7 Kgf/cm ²	110 PSI

RATING	Kgf/cm ²	PSI
BODY	21 Kgf/cm ²	299 PSI
SEAT	15.4 Kgf/cm ²	219 PSI

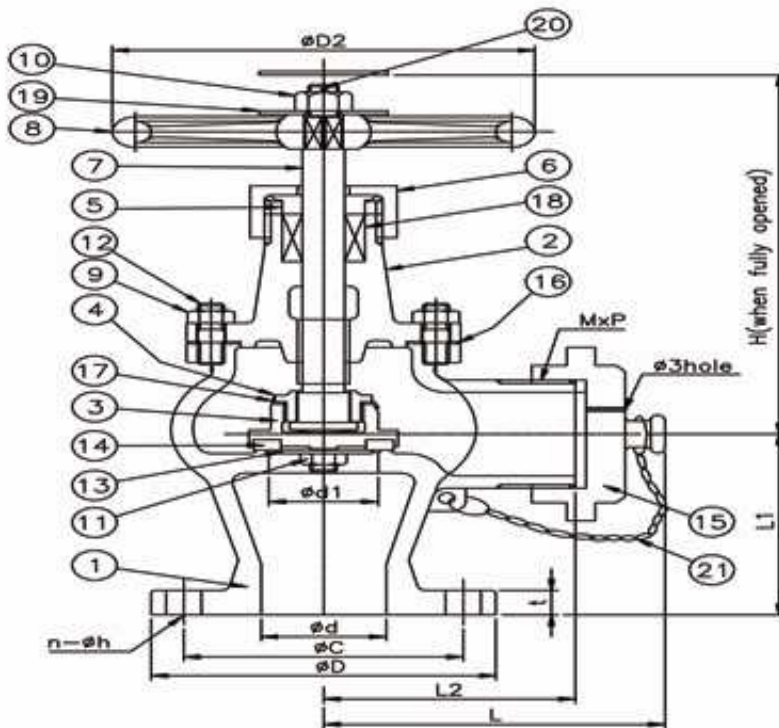

21	CHAIN	SUS304
20	SPLIT PIN	C2600W
19	NAME PLATE	C2801P
18	PACKING	TEFLON
17	DISC LOCK WASHER	C2600P
16	GASKET	NON-ASBESTOS
15	CAP	BC6
14	DISC	TEFLON
13	DISC SHEET	C3771BD
12	STUD BOLT	SUS304
11	HEXAGON NUT	SUS304
10	HEXAGON NUT	C3604BD
9	HEXAGON NUT	SUS304
8	HANDWHEEL	FC200
7	STEM	C3771BD
6	GLAND NUT	C3604BD
5	PACKING GLAND	C3771BD
4	VALVE DISC NUT	C3604BD
3	DISC HOLDER	BC6
2	BONNET	BC6
1	BODY	BC6

DIMENSION

(Unit:mm)

SIZE	ød	ød1	FLANGE JIS5k FF				L	L2	L1	H	øD2	MxP	WT(Kg) /EA
			øD	øC	n-øh	t							
50A	50	50	130	105	4-15	14	115	90	75	185	140	M64xP2	11.0
65A	65	65	155	130	4-15	14	131	106	90	215	160	M80xP2	22.0

SIZE	ød	ød1	FLANGE JIS10k FF				L	L2	L1	H	øD2	MxP	WT(Kg) /EA
			øD	øC	n-øh	t							
50A	50	50	155	120	4-19	16	115	90	75	185	140	M64xP2	14.3
65A	65	65	175	140	4-18	18	131	106	90	215	160	M80xP2	23.0

CAST IRON HOSE ANGLE 5K & 10K

RATING	Kgf/cm ²	PSI
BODY	10.5 Kgf/cm ²	149 PSI
SEAT	7.7 Kgf/cm ²	110 PSI

RATING	Kgf/cm ²	PSI
BODY	21 Kgf/cm ²	299 PSI
SEAT	15.4 Kgf/cm ²	219 PSI

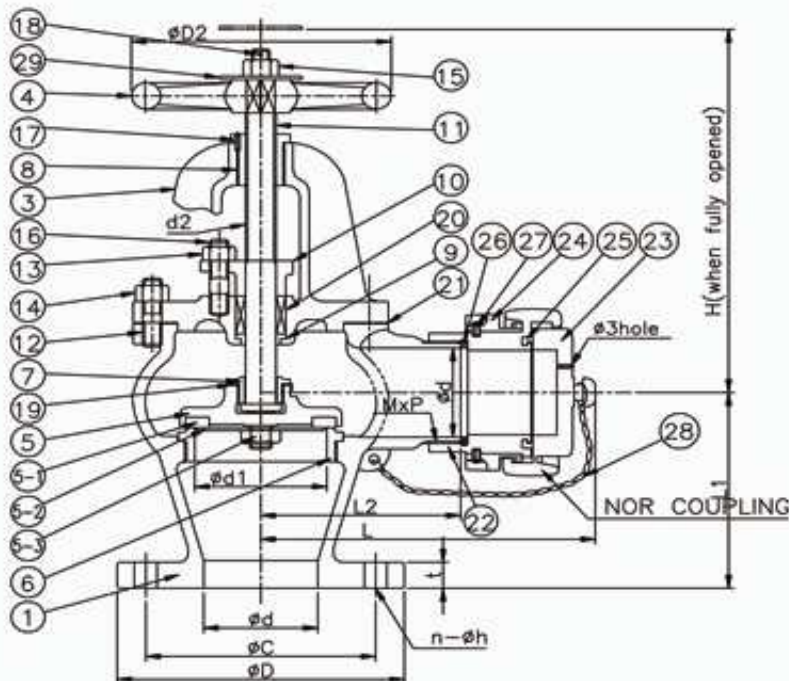

29	NAME PLATE	JIS H 3100-C2801P
28	CHAIN	JIS H 3260-C2600W
27	SET SCREW	SUS304
26	GASKET	NBR
25	PACKING	NBR
24	LOCK COUPLING	JIS H 5111-BC6
23	CAP	
22	HOSE BASE CONNECTION	JIS H 5111-BC6
21	GASKET	JIS F 7102
20	PACKING	
19	DISC LOCK WASHER	JIS H 3100-C2600P
18	SPLIT PIN	JIS H 3260-C2600 W
17	LOCK PIN	JIS G 3101-SS400
16	HEXAGON NUT	JIS H 3250-C3604 BD
15	HEXAGON NUT	JIS H 3101-SS400
14	HEXAGON NUT	JIS G 3101-SS400
13	STUD BOLT	JIS H 3250-C3771BD
12	STUD BOLT	JIS G 3101-SS400
11	STEM	JIS H 3250-C3771B0orBE
10	PACKING GLAND	JIS H 5111-BC6
9	BONNET BUSH	JIS H 5111-BC6
8	SCREWED BONNET BUSH	
7	DISC NUT	JIS H 5111-BC6 or JIS H 3250-C3771BD
6	VALVE SEAT	JIS H 5111-BC6
5-3	DISC LOCK NUT	JIS H 3250-C3771BD
5-2	DISC SHEET	JIS H 3250-C3771BD
5-1	DISC	TEFLON
5	DISC HOLDER	JIS H 5111-BC6
4	HANDWHEEL	FC200
3	BONNET	FC200
1	BODY	

DIMENSION

(Unit:mm)

SIZE	ϕd	FLANGE JIS5K FF				L	L ₁	L ₂	H	MxP	ϕd_1	d ₂	ϕD_2	WT(Kg) /EA
		ϕD	ϕC	n- ϕh	t									
50A	50	130	105	4-15	16	176	100	100	240	M64xP2	50	TW20	160	9.6
SIZE	ϕd	FLANGE JIS10K FF				L	L ₁	L ₂	H	MxP	ϕd_1	d ₂	ϕD_2	WT(Kg) /EA
		ϕD	ϕC	n- ϕh	t									
50A	50	155	120	4-19	20	170	120	115	255	M64xP2	50	TW22	160	12.7
65A	65	175	140	4-19	22	185	130	125	270	M80xP2	65	TW24	200	20.4